



# SEED SHUTTLE SS290



Heavy duty trailer option



2 - 145 unit poly tanks with independent slide controls

## ***The Future of Seed Tenders is Here!***

The all ***NEW SEED SHUTTLE SS290*** is the first all non-corrosive poly tank Seed Tender on the market today. It has unique features such as both side and rear discharge unloading positions, and a heavy duty frame designed for tough commercial and farm use. In addition to easy seed handling, you will soon be able to use your ***SEED SHUTTLE SS290*** as a water tank as well... making it the most versatile tender on the market.

# SEED SHUTTLE SS290

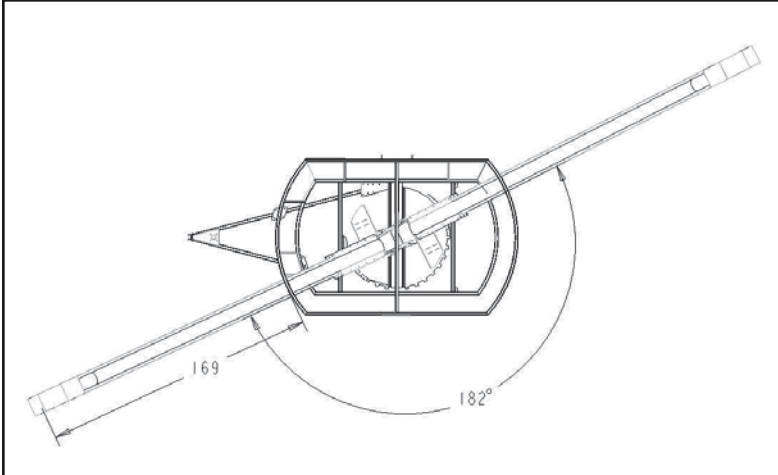

180 degree conveyor swivel with both side and rear unloading positions



8" diameter tube, 10" wide all rubber belt and a 23' long conveyor for extra reach



2 – 45" X 27" sealed lid openings with 18" wide catwalk



5.5 Honda motor, battery and variable flow controls

## Features of the SS290:

- 180 degree conveyor swivel with both side and rear unloading positions
- 2 – 145 unit poly tanks with independent slide controls
- 2 – 45" X 27" sealed lid openings
- 8" diameter tube 23' long conveyor for extra reach
- 10" wide all rubber belt
- Enclosed belt on return of conveyor
- 17 locking positions on the conveyor
- Transport lock on the conveyor for safety
- 3 piece telescoping downspout with end variable flow controls
- 5.5 Honda motor, battery and variable flow controls
- 18" wide catwalk with side ladder access
- Powder Coated frame
- Heavy Duty Frame (4000LB approximate weight)

## SS290 Options:

Trailer with 2-7000lb torsion axles and adjustable hitch

Weigh scales

## NORWOOD SALES INC.

Two locations to serve you.

Cooperstown, ND 58425

Phone: 701-797-3684

FAX: 701-797-3685

Union, NE 68455

Phone: 402-263-2100

FAX: 402-263-2104

Toll Free: 800-446-0316